

Ignition Coil PS-T

www.bosch-motorsport.com



- ▶ Max. 27 kV
- ▶ Max. 42 mJ
- ▶ Max. 1.5 kV/μs
- ▶ Max. 10,000 1/min

This pencil coil is a basic low cost concept designed for cylinder head installation. The coil PS-T has an integrated transistor and requires an ECU with internal ignition drivers. The coil is only designed for spark plug shaft mounting. It is a basic concept for ignition applications.

Application

Spark energy	≤ 42 mJ
Primary current	≤ 7.5 A
Operating temperature range at outer core	-20 to 140°C
Storage temperature range	-40 to 100°C
Max. vibration	≤ 800 m/s ² at 5 to 2,500 Hz

Technical Specifications

Mechanical Data

Diameter	22 mm
Weight	202 g
Mounting	Screw fastening

Electrical Data

Primary resistance with wire	Incapable of measurement
Secondary resistance	Incapable of measurement
High voltage rise time	≤ 1.5 kV/μs
Max. high voltage at 1 MΩ 10 pF	≤ 27 kV
Spark current	≤ 80 mA
Spark duration at 1 kV 1 MΩ	≤ 1.1 ms
Noise suppression	Inductive
Suppression diode / EFU	Integrated
Power stage	Integrated

Characteristic

Measured with power stage	BIP 355
---------------------------	---------

Connectors and Wires

Connector	Bosch Compact
Mating connector 4-pole Compact	D 261 205 336-01

Pin 1	ECU ignition signal
Pin 2	ECU GND
Pin 3	Engine GND
Pin 4	U _{batt}

Various motorsport and automotive connectors are available on request.

Characteristic dwell times [ms]

U _{batt}	I _{primary}					
	4.0A	5.0A	6.0A	7.0A	8.0A	9.0A
6V	2.90	4.20	6.30	14.4	-	-
8V	1.83	2.45	3.17	4.10	5.10	6.20
10V	1.33	1.74	2.18	2.68	3.16	3.49
12V	1.05	1.35	1.68	2.02	2.33	2.53
14V	0.86	1.11	1.35	1.62	1.85	1.99
16V	0.73	0.93	1.14	1.35	1.54	1.65
20V	0.56	0.71	0.86	1.02	1.15	1.23
22V	0.50	0.64	0.77	0.91	1.02	1.09
24V	0.46	0.58	0.70	0.82	0.92	0.98

Measured values are without loom resistance. Loom resistance must be less than the primary resistance. The needed dwell time is to be verified through current measurement

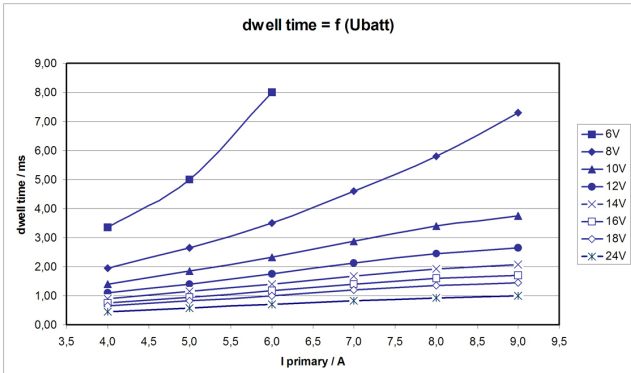

Dwell time

Spark energy and provided high voltage

I _{prim.}	Spark energy	-duration	-currant	Hi voltage
4 A	15.0 mJ	0.650 ms	46 mA	15.6 kV
5 A	22.8 mJ	0.793 ms	62 mA	19.3 kV
6 A	30.2 mJ	0.904 ms	73 mA	22.7 kV
7 A	38.2 mJ	1.010 ms	84 mA	26.0 kV
8 A	47.9 mJ	1.101 ms	96 mA	28.8 kV
9 A	52.9 mJ	1.130 ms	100 mA	30.2 kV

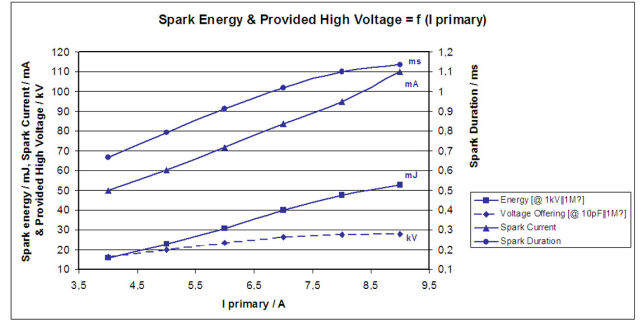

Spark energy

Installation Notes

During mounting of the spark plug please pay attention that full clamping and proper contacts are made to ensure safe connection between coil and spark plug.

The coil PS-T has an integrated transistor and requires an ECU with internal ignition drivers, e.g. MS 4.x or MS 4.x Sport.

For technical reasons the values of the coils may vary.

Please regard the specified limit values.

Please find further application hints in the offer drawing at our homepage.

In case of ignition-caused malfunctions, please use screened sensor wires.

Ordering Information

Ignition Coil PS-T

Order number **0 221 604 103**

Dimensions

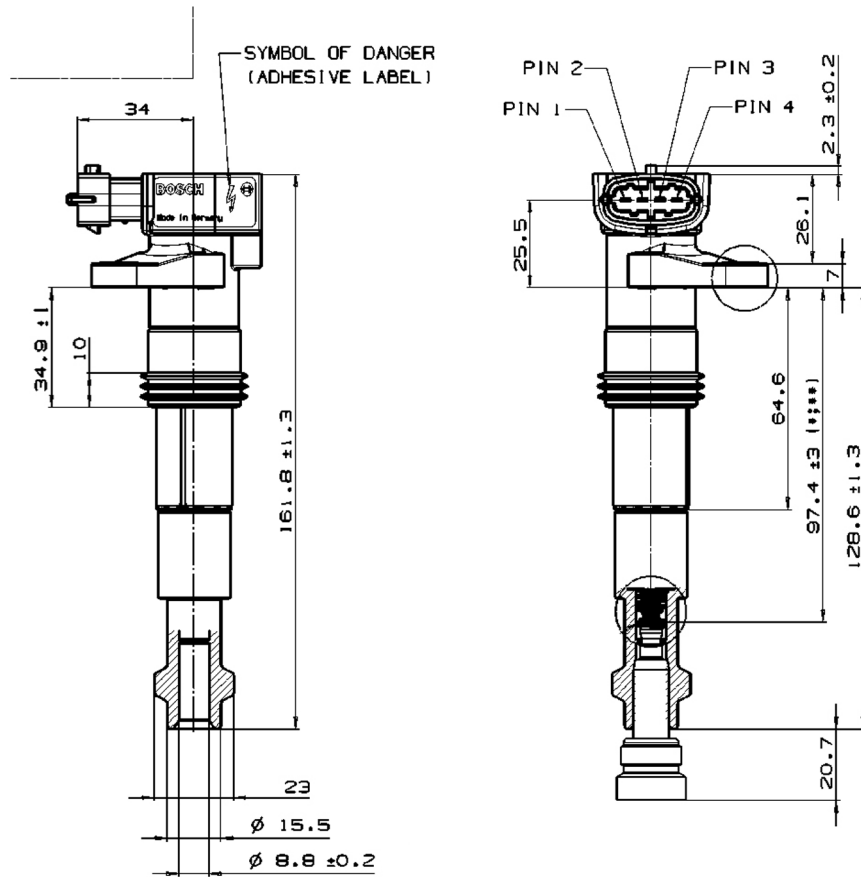

Represented by:

Europe:
 Bosch Engineering GmbH
 Motorsport
 Robert-Bosch-Allee 1
 74232 Abstatt
 Germany
 Tel.: +49 7062 911 9101
 Fax: +49 7062 911 79104
 motorsport@bosch.com
 www.bosch-motorsport.de

North America:
 Bosch Engineering North America
 Motorsport
 38000 Hills Tech Drive
 Farmington Hills, MI 48331-3417
 United States of America
 Tel.: +1 248 876 2977
 Fax: +1 248 876 7373
 motorsport@bosch.com
 www.bosch-motorsport.com

Latin America:
 Robert Bosch Ltda
 Motorsport
 Av Juscelino Kubitscheck de
 Oliveira 11800
 Zip code 81460-900
 Curitiba - Parana
 Brasilia
 Tel.: +55 41 3341 2057
 Fax: +55 41 3341 2779

Asia-Pacific:
 Bosch Engineering Japan K.K.
 Motorsport
 18F Queen's Tower C, 2-3-5 Minato Mirai
 Nishi-ku, Yokohama-shi
 Kanagawa 220-6218
 Japan
 Tel.: +81 45 650 5610
 Fax: +81 45 650 5611
 www.bosch-motorsport.jp

Australia, New Zealand and South Africa:
 Robert Bosch Pty. Ltd
 Motorsport
 1555 Centre Road
 Clayton, Victoria, 3168
 Australia
 Tel.: +61 (3) 9541 3901
 motor.sport@au.bosch.com